

PROJECT	QUANTITY	ITEM NO
---------	----------	---------

Shortening Shuttle®

FS 100
FS 200



Shortening Shuttle® FS 200

1. Drain used oil from fryer
2. Transport to appropriate container
3. Set spout on rim
4. Tip end up to empty shuttle

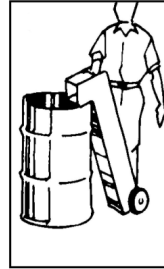
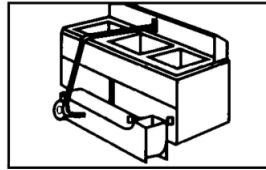

The Shortening Shuttle® is designed specifically for draining and transporting hot frying oil from open fryers to proper disposal containers. When properly used, the shuttle helps avoid spills and other safety concerns by eliminating the need to lift and carry hot oil in an open container.

- FS 100 spout height designed for a standard 55 gallon drum
- FS 200 spout height designed for a dumpster-type container up to 48 in (1219 mm) high

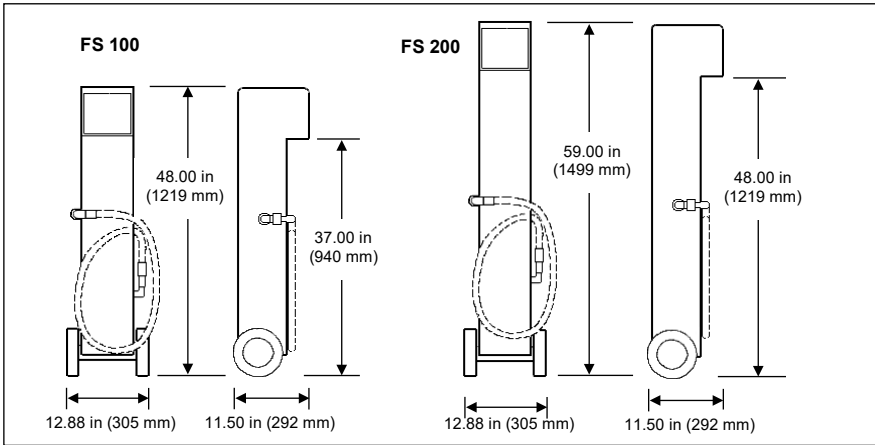

Standard features

- Lightweight aluminum body for easy handling
- Flexible drain hose with quick disconnect for convenience
- Available with male or female disconnects
- Reinforced, end-mounted wheel assembly with large 8 in (203 mm) wheels for easy pivoting and transport
- Spout provides leverage for pivoting wheel end up—*employees never have to lift loaded shuttle*
- Stainless steel wall hook mounts shuttle securely against wall in upright position when not in use

	FS 100	FS 200
--	--------	--------

Dimensions

Width	12.88 in (305 mm)	12.88 in (305 mm)
Depth	11.50 in (292 mm)	11.50 in (292 mm)
Height	48.00 in (1219 mm)	59.00 in (1499 mm)
Weight	25 lb (11 kg)	30 lb (14 kg)

Crated

Width	15 in (380 mm)	16 in (406 mm)
Depth	12 in (305 mm)	15 in (380 mm)
Height	49 in (1245 mm)	59 in (1500 mm)
Volume	5.1 ft ³ (0.14 m ³)	8.2 ft ³ (0.23 m ³)
Weight	29 lb (13 kg)	37 lb (17 kg)

Capacity hot frying oil

Volume	31 qt (29 L)	36 qt (34 L)
Weight	60 lb (27 kg)	70 lb (32 kg)

Bidding Specifications

Provide Shortening Shuttle® FS100 or FS 200 for use in safely draining, transporting and disposing of spent hot frying oil. FS 100 is sized for disposal into standard 55 gallon drums. FS 200 is sized for larger dumpster containers.

Units shall incorporate:

- Containment body constructed of integral lightweight aluminum
- Flexible hose with quick disconnect fitting for use with all Henny Penny filtration-equipped fryers
- 8 in (203 mm) wheel assembly

Continuing product improvement may subject specifications to change without notice.

<input type="checkbox"/> APPROVED	<input type="checkbox"/> APPROVED AS NOTED	<input type="checkbox"/> RESUBMIT
AUTHORIZED SIGNATURE		DATE

Henny Penny Corporation
PO Box 60 Eaton OH 45320 USA
+1 937.456.8400 800.417.8417
+1 937.456.8434 Fax 800.417.8434 Fax
+1.800.417.8405 Technical Support
www.hennypenny.com

HENNY PENNY
Engineered to Last