

PROJECT	QUANTITY	ITEM NO
---------	----------	---------

Rotisserie Countertop electric



MODEL **SCR-6** six-spit



SCR-6 countertop 6-spit rotisserie

General Information

Henny Penny rotisseries are known for turning out full loads of consistently delicious rotisserie items day after day, all day long.

What makes Henny Penny different? You'll get *more* of those delicious whole birds, ribs, pork roasts and other center-of-the plate items every day because the Henny Penny rotisserie simply cooks faster. Patented THERMA-VEC® Even Heat Process combines cross-flow convection cooking with radiant heat. The result is thorough, even cooking with uniform browning in a lot less time than other rotisseries.

The single cabinet SCR-6 six-spit countertop rotisserie saves on floor space while cooking a hefty 24 whole birds in a single load. With nine individual cooking programs available you also have the ability to

cook a wide range of menu items at the touch of a button. What's more, the sophisticated yet easy-to-use controls let you choose the level of browning you want! Now you can give seasoned and marinated meats, fish and poultry just the right color and crispness that brings customers back for more.

Henny Penny offers a host of accessories including mobile loading stands, product display units, and merchandising bases that increase your productivity and help you sell more. Spits, rotor disks, drive tube and drip trays are easily removed for cleaning and are available with coated surface.

Standard Features

- High quality stainless steel construction, exterior and interior.
- THERMA-VEC® Even Heat Process cooks full loads quickly and evenly:
 - Gentle, cross-flow convection for even cooking throughout the cabinet.
 - Radiant heat for uniform browning and crisp texture.
- Digital electronic controls with 9 programmable cook cycles.
- Programmable browning and texture control.
- Large LED display for simultaneous time and temperature.
- Food temperature probe.
- Spit rotation switch for easy loading.

- Tempered clear glass doors with black matrix shaded borders.
- Auto-stop rotation when doors open.
- Interchangeable spits, racks and baskets.
- Simple three-piece drive tube and rotor assembly.
- Drive assembly, drip trays and drain pans are easily disassembled for quick cleanup.
- Easy-to-clean coated parts available for additional charge.

Options

- Curved tempered glass outer door, customer side
- Lamp guards
- Coated parts

Choose standard configuration

- 6 angled spits OR
- 6 piercing spits OR
- 6 solid bottom baskets OR
- 6 wire baskets
- Customer-side door handle
 - with without
- Customer-side rotation switch
 - with without
- Control-side door glass
 - Clear with black matrix shading
 - Mirrored with black matrix shading
- Mobility
 - 4 casters 4-inch (102 mm)
 - Adjustable leveling legs
 - No casters or leveling legs

<input type="checkbox"/> APPROVED	<input type="checkbox"/> APPROVED AS NOTED	<input type="checkbox"/> RESUBMIT
AUTHORIZED SIGNATURE		DATE



Rotisserie

Countertop electric

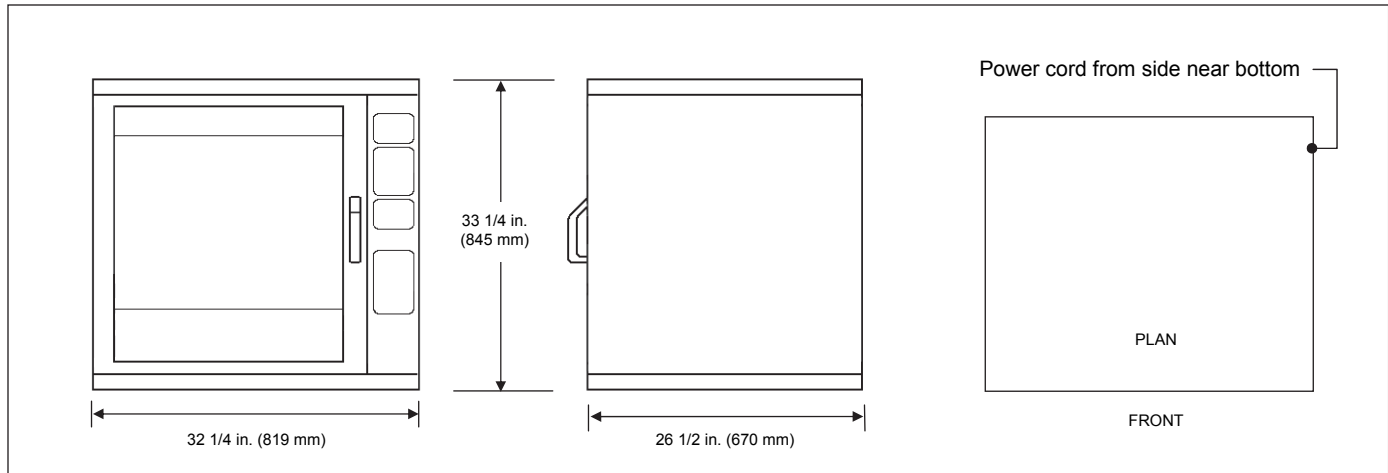
MODEL **SCR-6** six-spit

Dimensions

Height: 33 1/4 in. (845 mm)
 Width: 32 1/4 in. (819 mm)
 Depth: 26 1/4 in. (670 mm)

Required clearances:

Left: 2 in. (50 mm) air flow
 Right: 20 in. (500 mm) service access, power cord
 Back: 28 in. (711 mm) door open
 Front: 28 in. (711 mm) door open

Crated dimensions

Length: 40 in. (1016 mm)
 Depth: 33 3/4 in. (857 mm)
 Height: 42 in. (1067 mm)
 Volume: 32.8 cu. ft. (0.93 m³)

Net weight: N/A

Crated weight: 381 lbs. (173 kg)

Water connections: N/A

Heating: Electric convection and radiant heat

Lighting: 4 tungsten halogen lamps 150W

Capacity: 2 1/2 lbs. (1.1 kg) whole birds
 Angled spits 18 whole birds, 3 per spit
 Piercing spits 24 whole birds, 4 per spit
 Basket 18 whole birds, 3 per spit

Electrical

Volts	Phase	Cycle/Hz	Watts	Amps	Wire	Plug
208	1	50/60	6800	32.7	2+G	NEMA 6-50P
240	1	50/60	6800	28.3	2+G	
208	3	50/60	6800	22.8	3+G	NEMA 15-30P
240	3	50/60	6800	19.7	3+G	
400	3	50	6800	13.5	3NG	N/A

Laboratory certifications



Bidding Specifications

- Provide Henny Penny model SCR-6 six-spit countertop electric rotisserie.
- Unit shall be constructed of high-quality stainless steel interior and exterior, with tempered door glass.
- Unit shall feature patented Therma-Vec Even Heat Process that combines cross-flow convection heat with radiant heat for fast, even cooking and browning.
- Unit is programmable and features large LED displays for time and temperature.
- Food probe and probe cooking capability is standard.
- Unit shall allow customer-controlled browning levels to be input as part of a cooking program.
- Standard unit is pass-through design.
- Choice of handle, curved outer door glass and rotation switch for customer side and service side.
- Choice of 6 angled or piercing spits, or baskets is standard.
- Spits, rotor disks, drive tube and drip trays are removable for cleaning and are available coated.
- Choice of 4 casters 4 in. (102 mm) or leveling legs.
- Power cord and plug are shipped with 3-phase units, USA and Canada destinations only.

Continuing product improvement may subject specifications to change without notice.

Henny Penny Corporation
 PO Box 60 Eaton OH 45320 USA
 +1 937 456.8400 800 417.8417
 +1 937 456.8434 Fax 800 417.8434 Fax
www.hennypenny.com